

The 7th  
**INTERNATIONAL  
COIN-OPERATED  
LAUNDRY  
EXPO 2022**

**The 7th Coin-operated Laundry EXPO 2022**

2022  
Dec. 8 Thu. > 9 Fri.

Dec. 8 10:00-17:00

Dec. 9 10:00-16:00

**PACIFICO YOKOHAMA**

# The only coin-operated laundry trade show in Japan

Showcase of the latest products and services

- New exhibit area -  
Automated Self-Service System









The number of laundromat is increasing year by year in Japan. In addition, it is becoming more common to combine it with other services such as car wash, cafe, fitness gym, convenience store, etc..



Prestigious 7th awards for coin-operated laundry shop will be held during the show.

## Prospective Exhibitors

-  Machine / Equipment manufacturer
-  Equipment and materials dealer
-  Detergent manufacturer
-  Automated self-service system  
System vender, Delivery locker, Car wash, Vending machine, Fitness gym and other unstaffed store business

-  Materials manufacturer
-  Trading house / Agent  
(companies promoting coin-operated laundry business)
-  Franchiser / Franchisee
-  etc. (House cleaning, Wash & fold laundry service, Store design, Security service provider, IT equipment supplier etc.)

## Prospective Visitors

- Coin-operated laundry owner
- Hotel / Hospital / Welfare facility
- Real estate
- Dry cleaner owner
- Franchise shop owner
- Commercial facility / Retail industry
- Investment company / Financial institution
- Gas station / Oil wholesaler
- Gas, electricity supplier
- Equipment / Material distributor
- Building cleaning
- House cleaning

## At A Glance

### 2019 TOKYO BIG SIGHT Show Results

#### Number of exhibitors

**63 companies 174 booths**

International Coin-operated Laundry EXPO 29 companies 109 booths  
Clean Business Forum 34 companies 65 booths

#### Number of Visitors (registered / counted)

**Registered 5,960 / Counted 10,365**

\*The above number includes visitors of joint exhibition.

### 2021 INTEX OSAKA Show Results

#### Number of exhibitors

**29 companies 78 booths**

International Coin-operated Laundry EXPO 15 companies 63 booths  
Clean Business Forum 16 companies 15 booths

#### Number of Visitors (registered / counted)

**Registered 1,577 / Counted 2,341**

\*The above number includes visitors of joint exhibition.

#### Visitor's categories

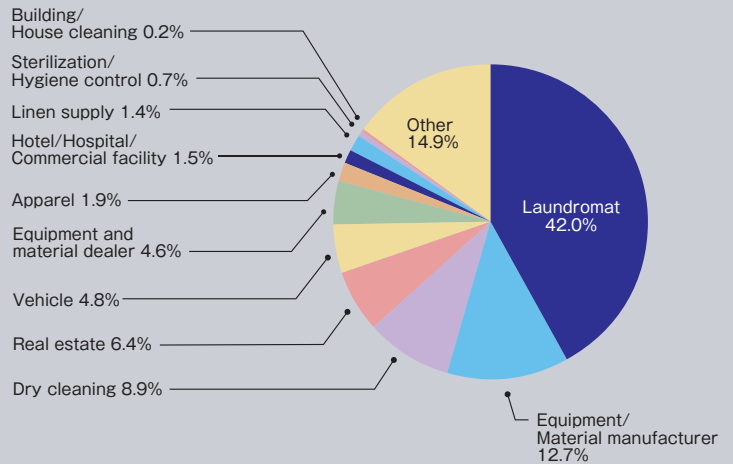

## Participation Scheme

#### Raw space

**JPY308,000**

(tax included) / booth (9sqm: 3m x 3m)

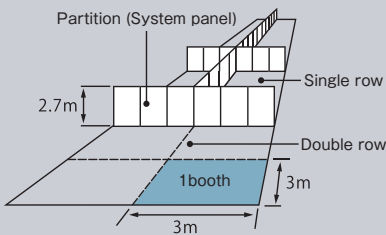

#### Shell scheme

**9sqm booth / JPY396,000**

(tax included)

- Company sign x 1
- Punch carpet x 1
- Reception counter x 1
- Visiting card box x 1
- Folding chair x 2
- LED light (20w) x 2
- LED Spotlight (5w) x 1
- Outlet (850w) x 1

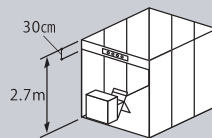

**18sqm booth / JPY770,000**

(tax included)

- Company sign x 1
- Punch carpet x 1
- Reception counter x 1
- Visiting card box x 1
- Folding chair x 2
- LED light (20w) x 4
- LED Spotlight (5w) x 2
- Outlet (850w) x 2

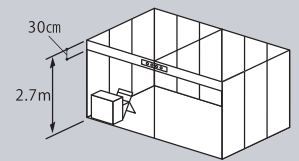

**Discount**

**Early Bird : JPY 1,000 / booth (Deadline : July 29, 2022)**

**2021 Exhibitor : JPY33,000 / booth**

## Ready-Built Compact Stand

Affordable stand specialized for sterilization/hygiene control, dry cleaning business and automated self-service zone.

#### Exhibit fee JPY 110,000 (tax included)

- Only for companies dealing with sterilization/hygiene control, dry cleaning business and automated self-service products and services.
- As a general rule, more than 2 units will be set up close together.
- If you would like to order other than the figure on the right, contact to the show management office to request for quotation.
- Please read Exhibition Rules on the reverse side of application form before applying.

#### A stand unit includes:

- Parapet (White) w99cm x h2.7m x 1
- Display counter (small storage with sliding doors) (White) w99cm x d70cm x h92cm x 1
- Company name board (Gothic/Black) w90cm x h20cm x 1
- Spotlight 75W x 1
- Outlet 100V (2 sockets) x 1
- Electricity · 500W

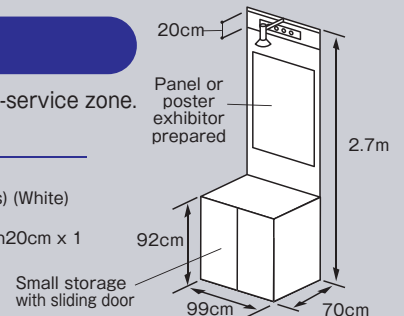

## Seminar Presentation

ICLE exhibitor is entitled to have a free presentation at the seminar room.

- 45min/1slot. Allocated time slot/schedule are subject to change by the organizer.
- This scheme is on a first come, first served basis.
- Basic video and audio equipments for the seminar will be provided.
- If you need a bilingual support, please ask the show management office for paid translation service in advance.

## Exhibition Timeline

2022  
April  
Start Applying  
for Exhibition

July 29th  
(Fri.)  
Early Bird  
Deadline

September 30th  
(Fri.)  
Application  
Deadline

December  
8 - 9

Contact

**Show Management Office**

c/o JC Resonance Co., Ltd. 1-12-2 Shirokane, Minato-ku, Tokyo 108-0072, Japan E-mail:office@jc-resonance.co.jp